

AO 01 Fissaggi per lavabi con tassello e boccola in nylon

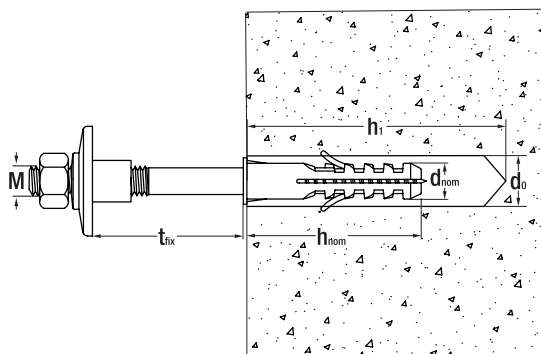

SCHEDA TECNICA



d_{nom}	diametro dell'ancorante
M	misura viti metriche
d_0	diametro del foro
h_1	profondità del foro
h_{nom}	profondità minima di inserimento
t_{fix}	spessore massimo fissabile

SCHEDA TECNICA AO 01

Codice Articolo	Misura tassello $d_{nom} \times h_{nom}$ (mm)	Misura Vite $M \times L_v$ (mm)	M	t_{fix} (mm)	d_0 (mm)	h_1 (mm)
AO 01 10 120	12 x 60	M10 x 120	10	30	12	75
AO 01 10 180	12 x 60	M10 x 180		80		

Materiale	Tipo di sollecitazione	AO 01
Calcestruzzo non fessurato C20/25 	Carico caratteristico ad estrazione $N_{r,k}$ (kN)	1,40
Calcestruzzo areato autoclavato 		1,00
Muratura forata 		0,70

7 In tabella sono indicati i CARICHI CARATTERISTICI per prove effettuate su diversi materiali tra cui calcestruzzo non fessurato, senza influenza del bordo e/o dell'interasse (valori di estrazione e taglio in kN: 1kN = 100Kg). Carichi caratteristici sono utilizzabili per la progettazione agli stati limite secondo l'ETAG020-Part C. Nel caso in cui si dovessero eseguire fissaggi su materiali diversi da quelli in tabella o in calcestruzzo fessurato, si renderà necessario effettuare ulteriori prove e/o usare diversi coefficienti di sicurezza.

AO 01

Dual thread screw with nylon washer and plug and zinc plated steel nut, for wash-basin fixing;



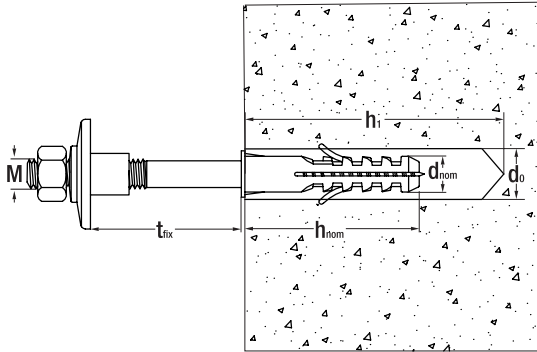

TECHNICAL DATA SHEET



d_{nom}	anchor diameter
M	metric
d_0	drill hole diameter
h_1	depth of drill hole
h_{nom}	minimum overall anchor embedment depth
t_{fix}	maximum thickness of fixture

TECHNICAL DATA SHEET AO 01

Item Code	Anchor Size $d_{nom} \times h_{nom}$ (mm)	Screw Size $d_s \times L_s$ (mm)	M	t_{fix} (mm)	d_0 (mm)	h_1 (mm)
AO 01 10 120	12 x 60	M10 x 120	10	30	12	75
AO 01 10 180	12 x 60	M10 x 180		80		

Material	Load direction	AO 01
Non-cracked concrete C20/25 	Characteristic resistance to tension load $N_{r,k}$ (kN)	1,40
Autoclaved aerated concrete 		1,00
Perforated masonry 		0,70

? Pull-out and shear showed in the table are CHARACTERISTIC LOADS from tests performed on non-cracked concrete C20/25 without edge and spacing effect (Pull-out and shear loads are in kN: 1kN = 100Kg). Characteristic loads can be used for limit state design according to ETAG020-Part C. In case you have to perform fixings on materials other than those in the table or in cracked concrete, it will be necessary to carry out further tests and / or use different safety factors.